

Raffle: A Solution for Lead Prospecting

Executive Summary

IO Progression is a company focused on helping professionals learn the latest cutting-edge technological platforms. Their main objective is to attract individuals who are interested in professional training as well as identify companies that concentrate on corporate training in strategic business areas.

The Challenge

IO Progression needed a simple and flexible platform that processes B2B data captured primarily at on site events and conventions. The platform was primarily designed to capture the contact information of prospects and decision makers for sales and marketing efforts in addition to awarding a raffle at the end of each event based on the data consumed at the event. The challenge was cost, speed, security and availability. Our solution and flow was carried entirely on Lambda functions.

Why AWS

AWS was selected for the range of services it offers, AWS Lambda being the support backbone of the entire platform and business rules are executed.

In addition to Lambda Functions, infrastructure provisioning is not necessary, reducing cost and paying only for what is used.

About Customer



“Earn a role-based certification that indicates you are keeping pace with today’s highly technical roles and requirements. Skill up, prove your expertise to employers and peers, and get the recognition and opportunities you’ve earned.”

“Serverless Solution”

- Cost Reduction by paying only for calls to the Lambda functions.
- No Infrastructure Provisioning.
- The backbone of the system are the Lambda functions.

The Solution

A serverless approach is followed for the construction of the system, the main points being:

- The solution has about 12 Lambda functions that control the business flow
- Lambda functions interact with other AWS services such as RDS and API Gateway
- There is a reduction in costs by paying only for the resources used
- Security layers are used when using services such as IAM and VPCs
- Optimum performance by Lambdas functions when invoked to store or consult information from the BD.

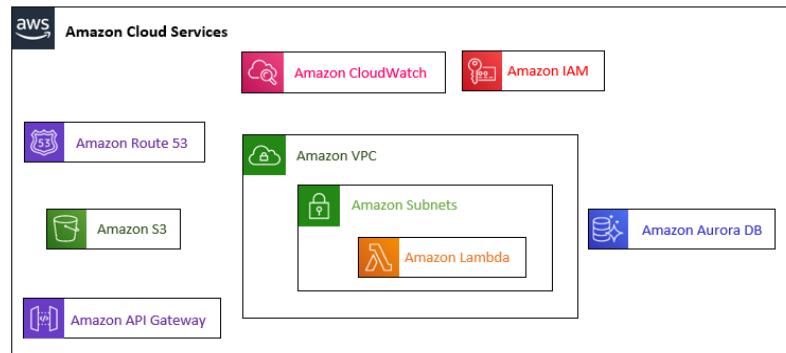

Results and Benefits

The main benefit is that there is a serverless approach where there is no need for infrastructure provisioning, in addition to other services such as RDS and API Gateway which are managed services.

Using this approach allows us to have a robust, modern and secure system in which the entire operation resides and there is also cost reduction by paying only for what is consumed.

Serverless Solution Diagram

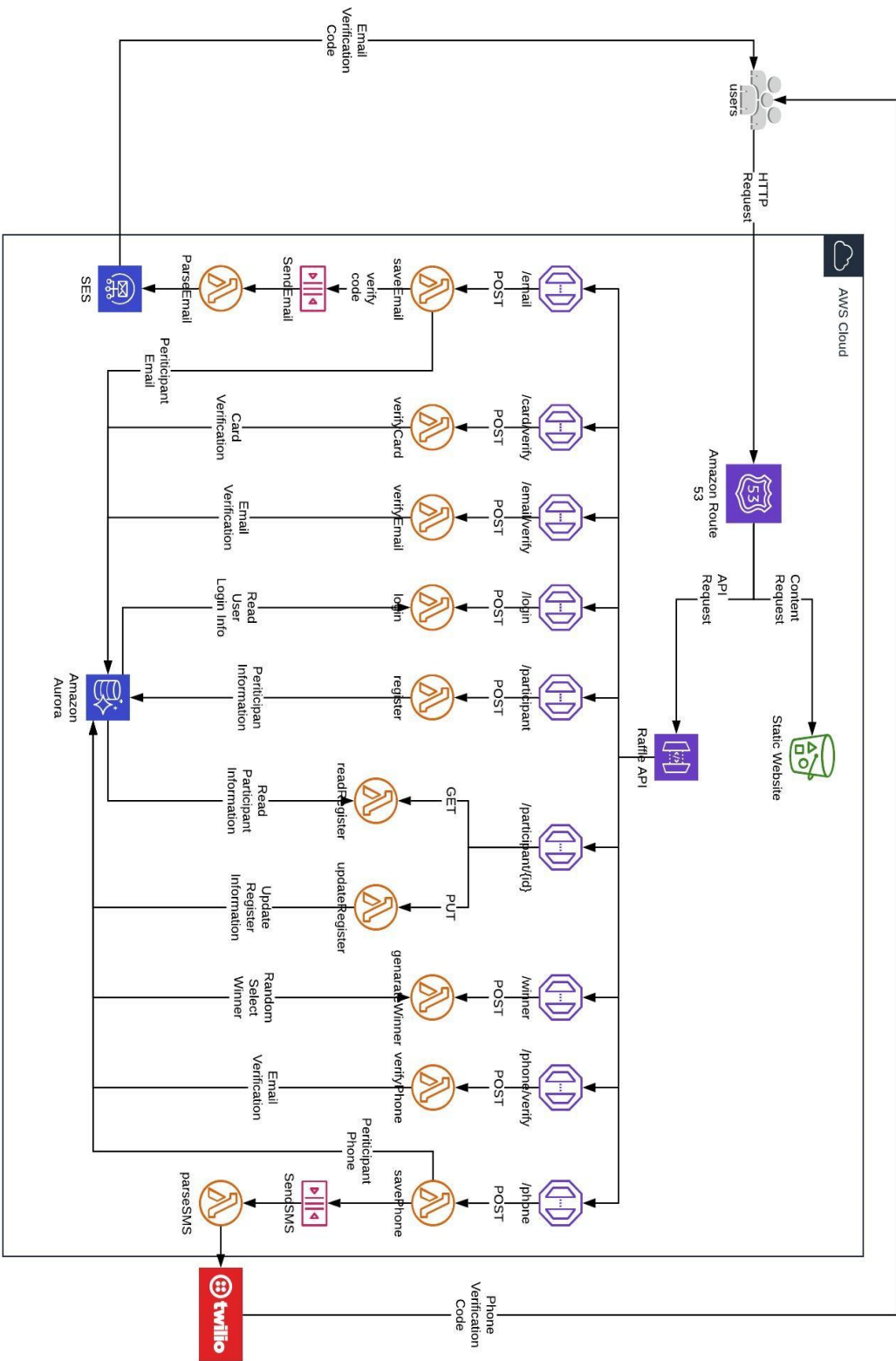

Next Steps

The application has been used in several national and international events demonstrating the power of Lambda functions in this type of applications. The operation has been so noticeable that other organizations have even approached to ask about the solution. A next step could be to try to commercialize the application as a product.

Benefits

Superior Performance

Serverless infrastructure provides a fast, hyperscale, cloud native and secure way to have the environment of the application. It also delivers access to data with millisecond latency, processes thousands of requests per second, and scale to support users anywhere in the world.

LOW TCO

Save money by replacing the physical hardware with expensive licensing fees with a serverless technology on AWS. Significantly reduce TCO with AWS serverless operational automation and free up resources to focus on your business instead of managing the infrastructure.

Fully Managed

With fully managed resource provisioning, maintenance, and backups, you no longer have to worry.

About IO Connect Services

IO Connect Services is a company specializing in Information Technology Consultancy Services. All our team members have one thing in common: our enthusiasm for technology and our passion for customer service excellence. We provide services in all North America, LATAM and Europe. Our headquarters are in the NYC metropolitan area and we also have offices in Guadalajara, Mexico and Madrid, Spain.

