

Using Amazon RDS for a fully Serverless Solution.

Executive Summary

Antiestatica offers a diversity of products and services related to the control of electrostatics, specifically lab coats and medical uniforms. Our completed project included a platform to control and monitor their electrostatic laundry process. This solution helps them harness data to manage product warranties, help avoid the loss of fabric antistatic properties and assisted them in accurate inventory forecasting.

The Challenge

Antiestatica's goal was to offer their customers a web management platform to visually monitor the washing cycle of their clothing for indications of wear and tear in order to make restocking decisions. Antiestatica also needed a solution that could scale accordingly in order to maximize new services and optimize their operations.

Antiestatica was aware that an on-premise solution was not an option based on total cost of ownership that this implies. Since the timelines were very aggressive, they contacted IO Connect Services as AWS experts to design and implement the right solution.

Why AWS

The main reason to choose AWS is because of the serverless portfolio that facilitates the creation of such infrastructure. The platform will be developed and hosted entirely on Amazon Web Services.

The Solution will provide services which consists in the allocation of technical resources in order to design, develop and implement the platform.

In addition, the solution uses a robust and secure database offered by the **RDS** service that let companies automate administrative tasks such as patching and backups since RDS is a managed service that makes easy any database implementation over the cloud.

About Customer



Antiestatica Grand Bison Industrial was founded in 2001 to offer a wide variety of products and services related to the control of electrostatic and clean rooms, supporting the processes and products of our customers to comply with ESD requirements and particle control according to current standards.

They started operations in Guadalajara, Mexico, attending only the local market, and over the years has implemented new distribution channels in different regions of the country.

“Serverless Solution”

- A physical infrastructure was out of the question, mostly because of the high initial cost and the need for scalability. Antiestatica looked to the cloud to help grow its business.
- Asynchronously Generated Reports.
- RDS for storing & querying the information
- Lambda functions are the core of the Launtra system
- Using managed services like RDS for easy implementation and administration.

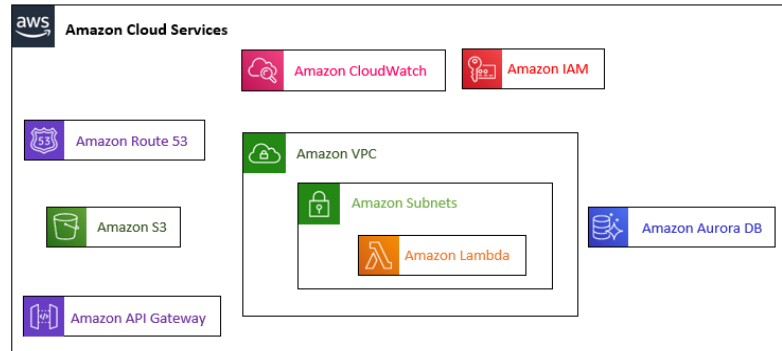

The Solution

In dealing with timely and budgetary constraints, our approach was to design a 100% AWS cloud native solution. The pillars of the solution are defined as follows:

- The React application is hosted and delivered via a S3 bucket.
- The requests made by the application will be resolved by API Gateway, which will be responsible for triggering a Lambda Function for each corresponding action.
- The database part will be implemented in AWS **RDS** Aurora, which guarantee consistent throughput and resiliency.
- On-demand reports that will be generated in an async and event-based approach using Lambdas and SQS queues.

Results and Benefits

Building a solution that is fully cloud native on AWS has enabled Antiestatica to grow and look for new ways to innovate for its customer. With the introduction of a Serverless architecture using AWS Lambda and API Gateway, the solution is guaranteed to provide an enhanced security and reliability to manage peaks of traffic safely.

Moreover, the reporting module provides the visibility of the data that was required to make business decisions promptly.

Another thing to consider is that the implementation of **RDS** as part of the solution add benefits like security, scalability and easy way to administer the database instance

Serverless Solution – General Diagram

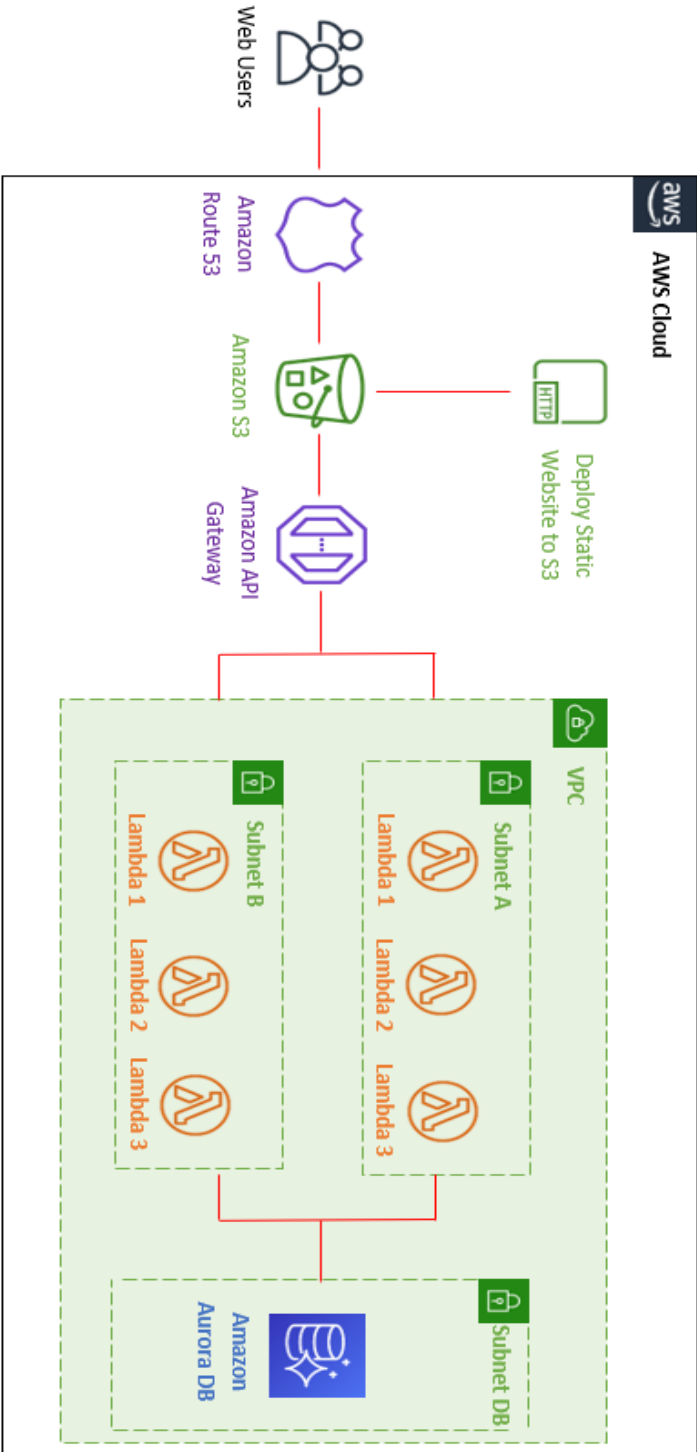

Database Architecture

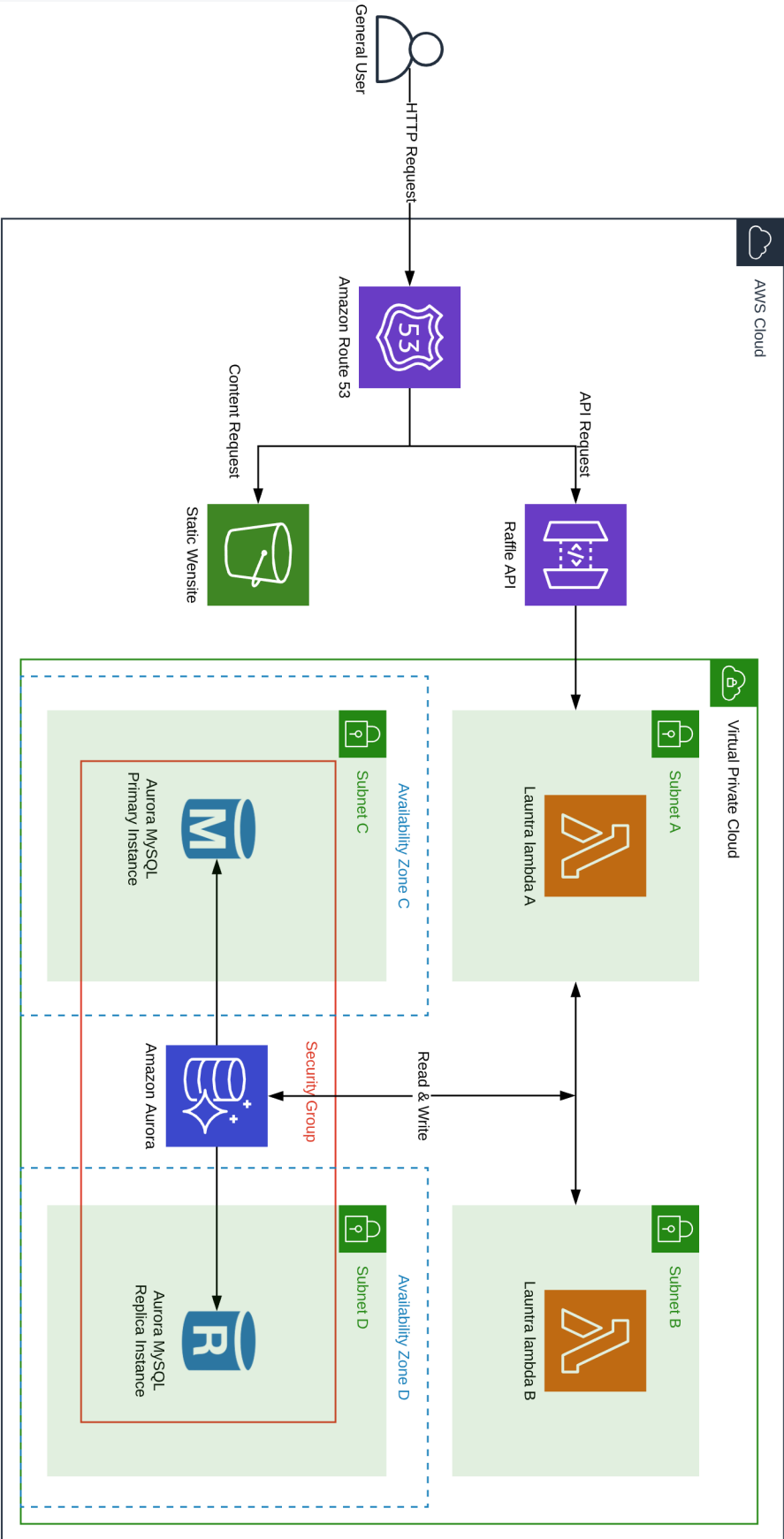

Serverless Solution - Login Diagram

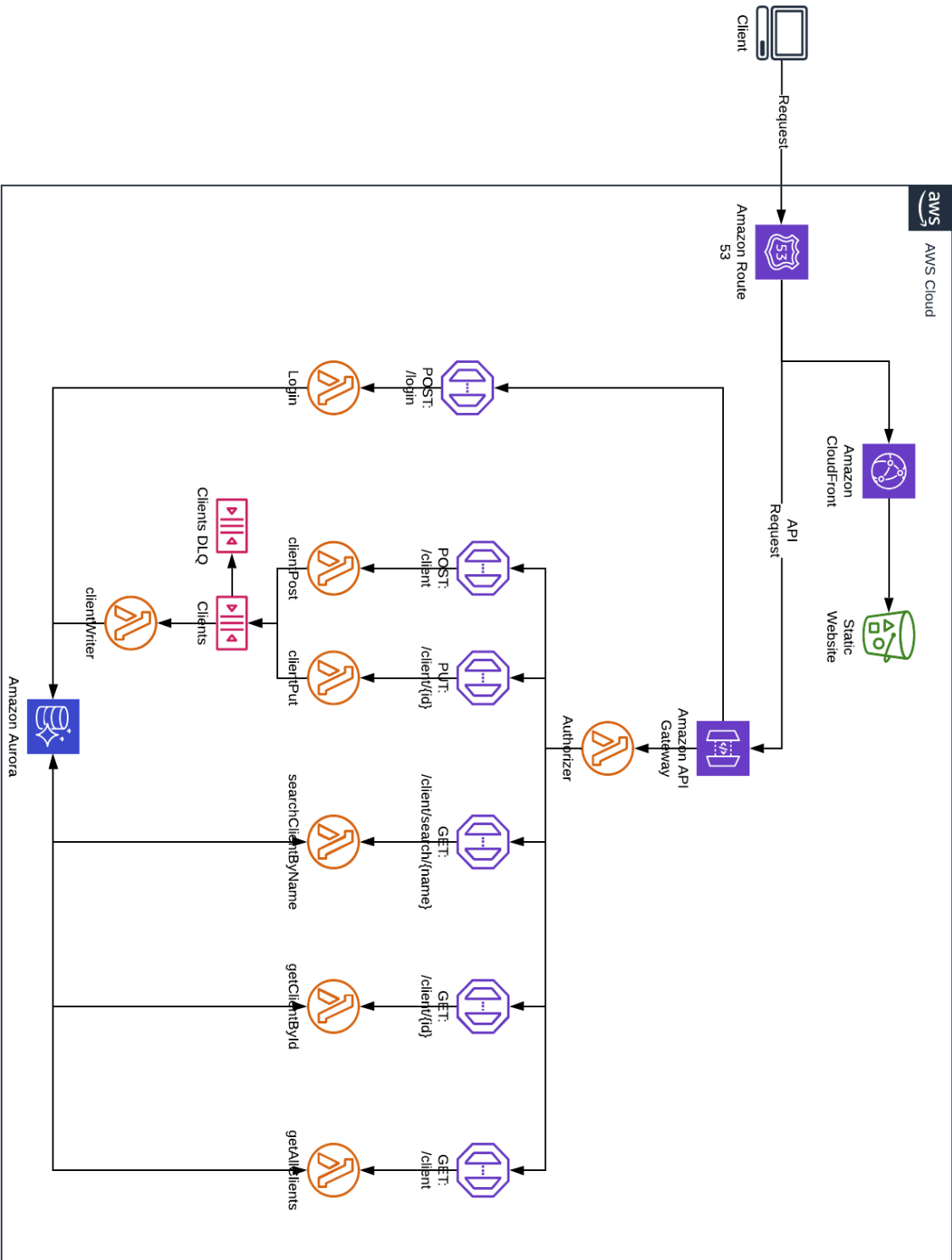

Serverless Solution - Laundry Diagram

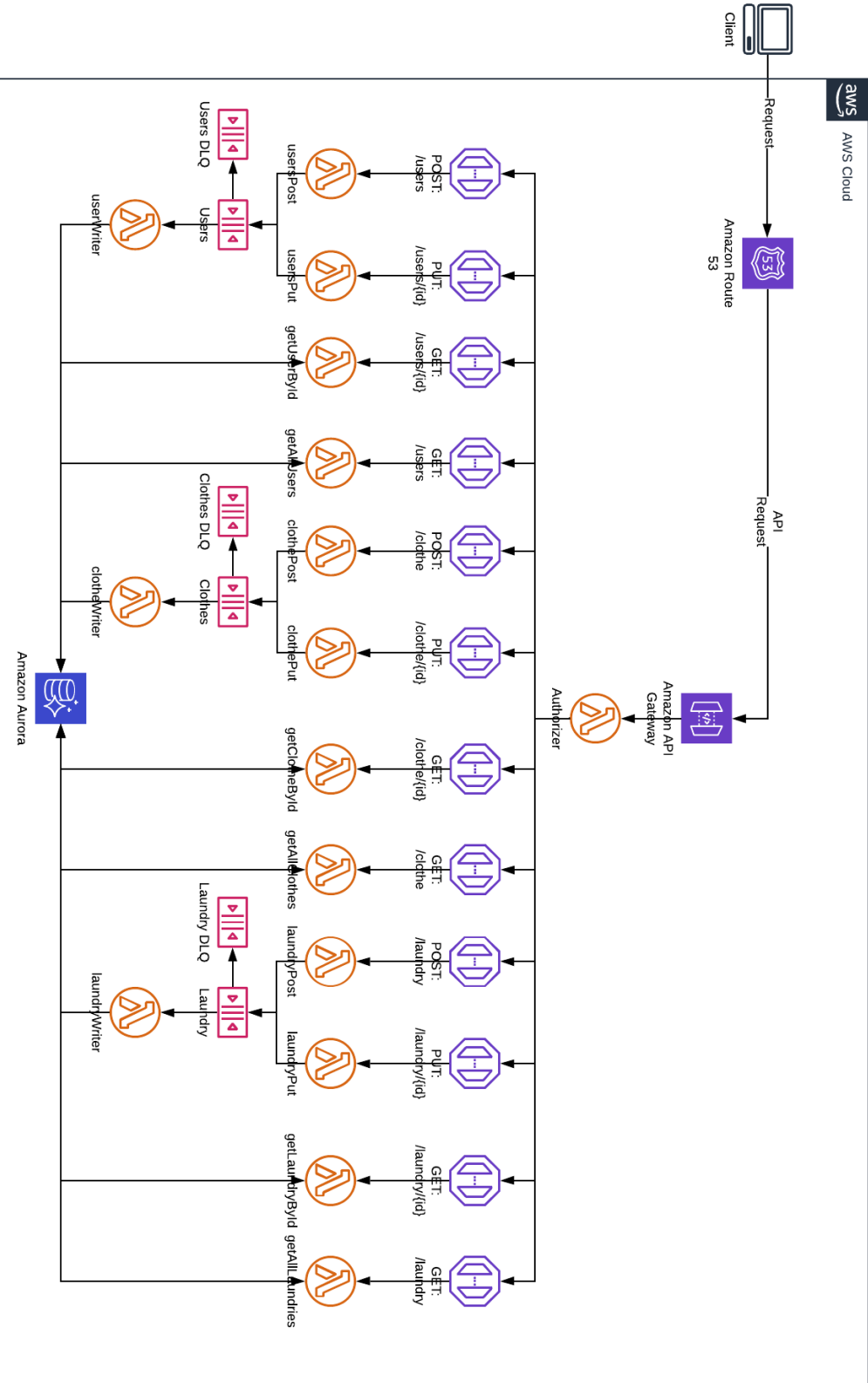

Serverless Solution – Loans Diagram

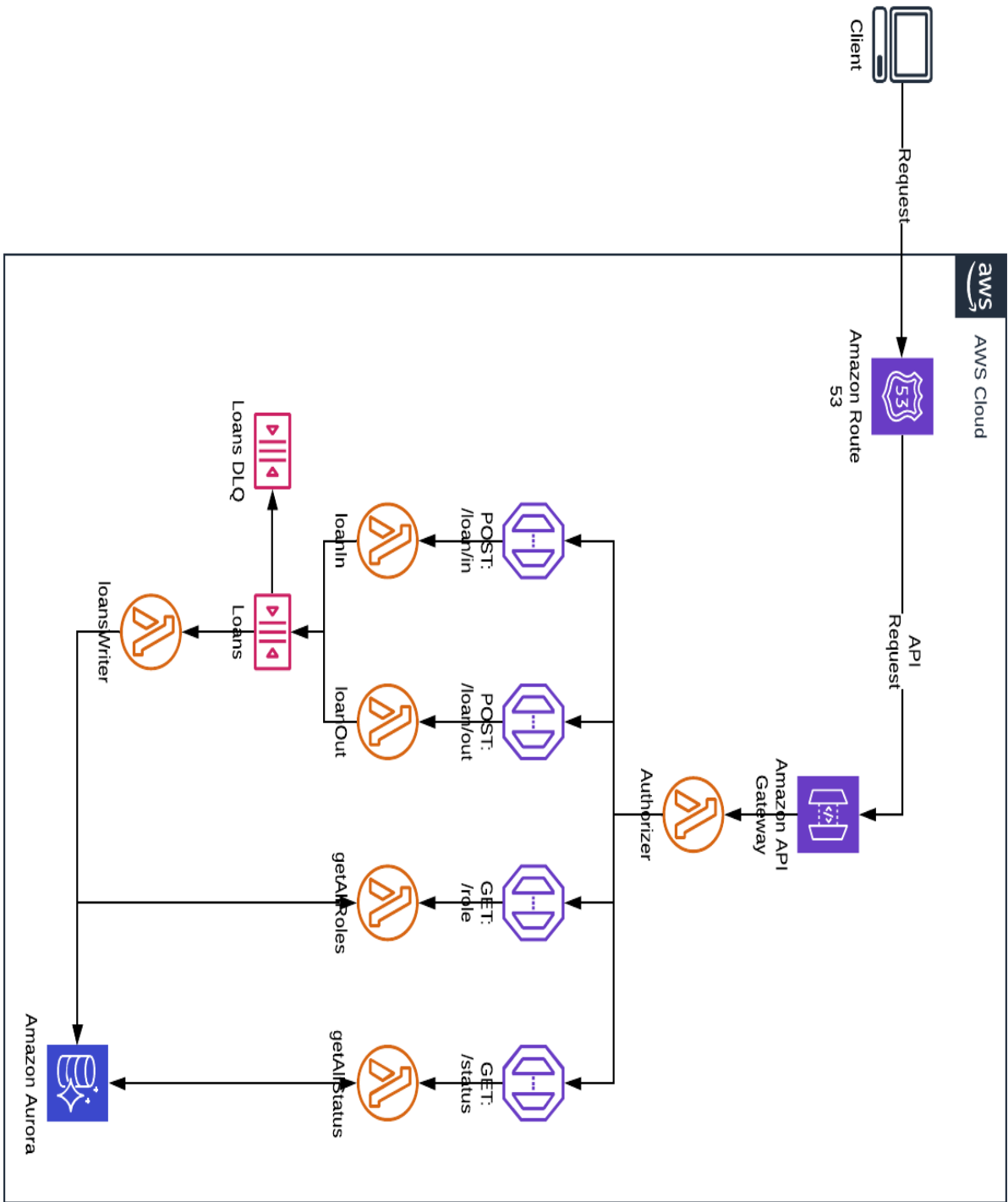

Serverless Solution – Reports Diagram

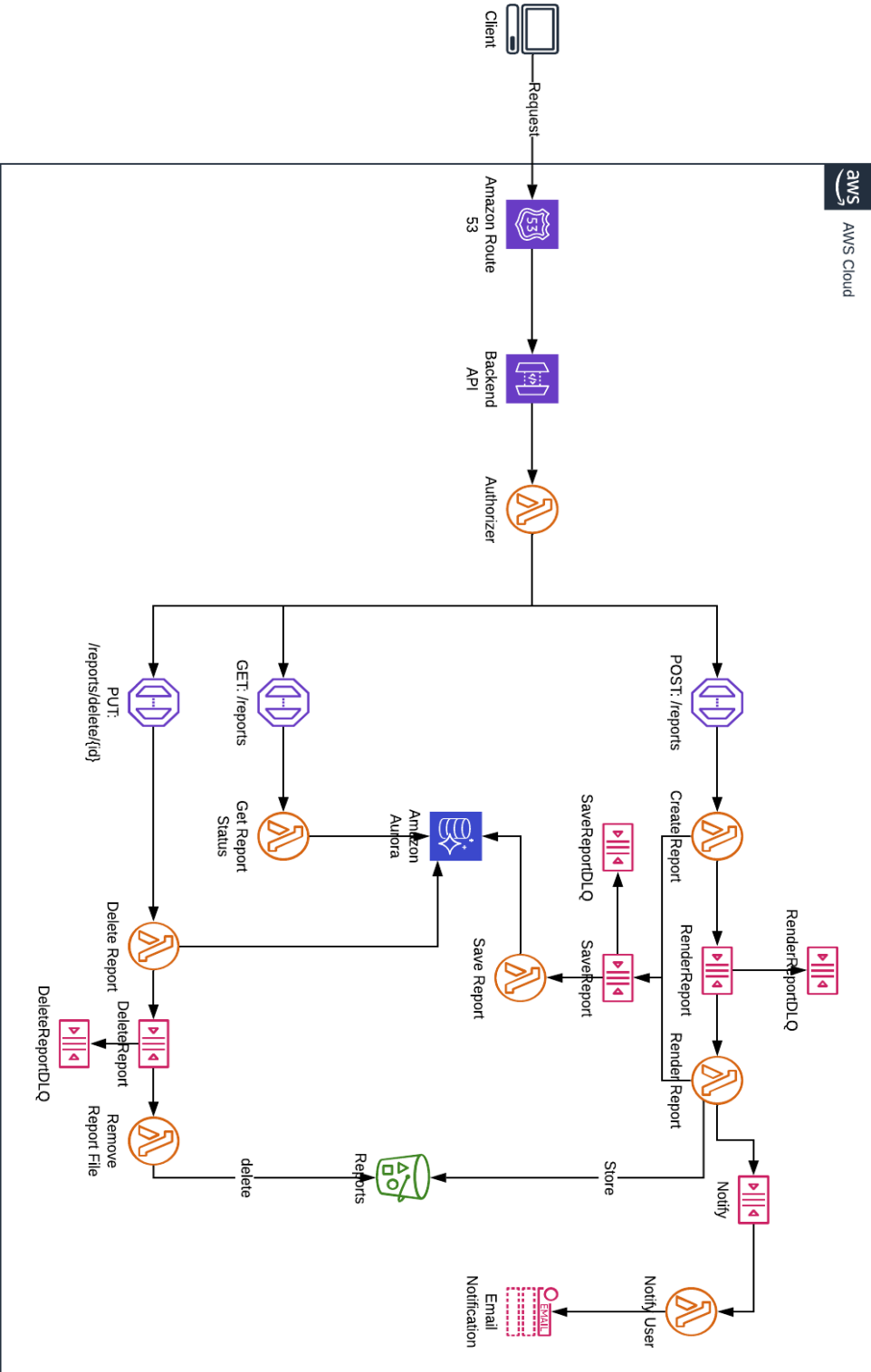

Next Steps

Now that the application was implemented on the cloud, it gives the opportunity to continuously improve and innovate the solution with other AWS technologies to provide real-time analytics and a data warehouse for business intelligence purposes.

The application will be leveraging monitoring (AWS CloudWatch) and logging (AWS CloudTrail) services. The data from these services will allow us to monitor resource usage, application performance, and operational health.

Benefits

Superior Performance

Serverless infrastructure provides a fast, hyperscale, cloud native and secure way to have the environment of the application. It also delivers access to data with millisecond latency, processes thousands of requests per second, and scale to support users anywhere in the world.

LOW TCO

Save money by replacing the physical hardware with expensive licensing fees with a serverless technology on AWS. Significantly reduce TCO with AWS serverless operational automation and free up resources to focus on your business instead of managing the infrastructure.

Fully Managed

With fully managed resource provisioning, maintenance, and backups, you no longer must worry.

About IO Connect Services

IO Connect Services is a company specializing in Information Technology Consultancy Services. All our team members have one thing in common: our enthusiasm for technology and our passion for customer service excellence. We provide services in all North America, LATAM and Europe. Our headquarters are in the NYC metropolitan area and we also have offices in Guadalajara, Mexico and Madrid, Spain.

